

ViewSonic® COMMERCIAL DISPLAY

CDE5014-2C

Key Features

- **Quad-Core SoC with 4 GB RAM** delivers smooth, stable performance.
- **Fast warm boot** launches signage and content in under seven seconds.
- **USB playback with signal failover** ensures continuous content delivery.
- **4K UHD in any orientation** provides sharp, professional visuals.
- **500-nit brightness and 24/7 operation** support reliable round-the-clock signage.

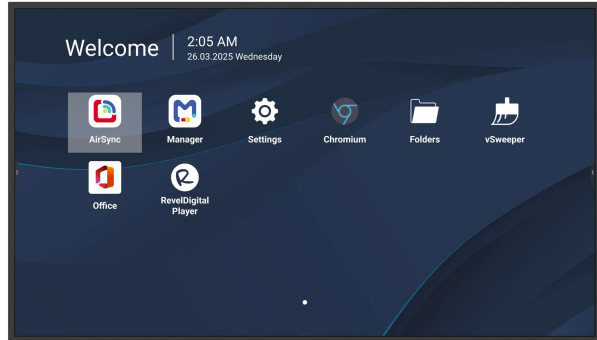

Product Description

The ViewSonic CDE14-2C Series is a commercial-grade 4K display built for 24/7 operation in offices, retail spaces, transit hubs, and other high-demand environments. Powered by Android 14 (upgradeable to Android 16) and a quad-coreSoC with 4 GB RAM, it supports smooth multitasking and fast warm boot for immediate startup. With 500 nits of brightness and support for both landscape and portrait modes, it delivers sharp, high-impact visuals for presentations and signage alike. Continuous USB media playback with automatic signal failover ensures uninterrupted content delivery, even when the primary source is lost. Designed for IT and AV professionals, the CDE14-2C Series integrates seamlessly with leading ProAV control systems and ViewSonic Manager for streamlined deployment and remote management. Whether deployed as a standalone unit or as part of a larger installation, it provides a dependable solution for corporate and commercial environments.

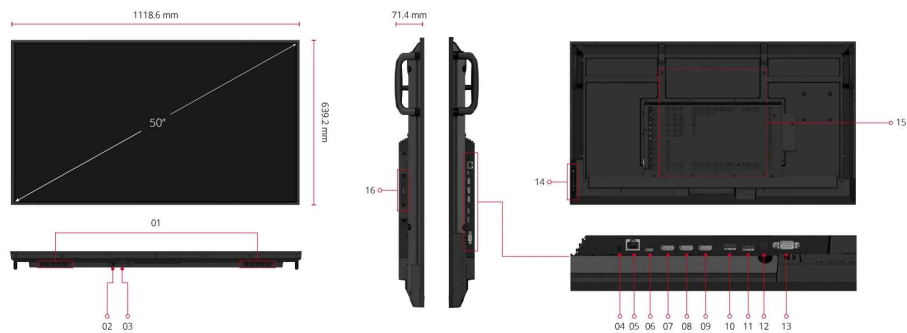

- | | | |
|-----------------|-------------------|----------------------------------|
| 1. Speaker | 8. HDMI 2 | 15. VESA® Wall Mount (400x400mm) |
| 2. Power Switch | 9. HDMI 3 | 16. WiFi Slot |
| 3. AC IN | 10. USB | |
| 4. Audio Out | 11. USB | |
| 5. LAN | 12. SPDIF | |
| 6. USB Type C | 13. RS232 | |
| 7. HDMI 1 | 14. Control Panel | |

Visit Us www.viewsonic.com

DISPLAY

Panel Size:	50"
Type/ Tech:	TFT LCD Module. DLED backlight
Display Area (mm):	1095.84(H) × 616.41(V) 50" diagonal
Native Resolution:	3840 x 2160
Aspect Ratio:	16:9
Colors:	8bit+FRC
Brightness:	500 nits (typ.)
Contrast Ratio:	5000:1 (typ.) / 5000:1 (DCR enabled)
Response Time:	8ms
Viewing Angles:	H = 178, V = 178 typ.
Backlight Life:	50,000 Hours
Surface Treatment:	Hardness: 3H, Anti-glare coating, Haze 25%
Bezel:	9.9/9.9/9.9/9.9 mm (L/R/T/B)
Orientation:	Landscape & Portrait

PLATFORM

Processor:	Quad-core ARM Cortex-A73
RAM:	4GB DDR4
Storage:	32GB

INPUT

HDMI:	x3 (HDMI 2.1 4K@60Hz*3, HDMI 3 supports ARC)
RS-232:	x 1
WiFi Slot:	x 1

OUTPUT

Audio:	3.5mm x1
SPDIF:	x 1

LAN

RJ45:	x1 (10/100M for USB Type-C)
-------	-----------------------------

USB

Type A:	USB2.0 x 2
Type C:	x1 (DP 1.2, USB 2.0, 15W PD, Ethernet sharing, Smart USB)

SPEAKERS

10W x 2

COMPATIBILITY

HDMI:	3840X2160 @60Hz
-------	-----------------

EMBEDDED OS

Android 14 AOSP

BUNDLED SOFTWARE

Wireless Presentation:	AirSync
Device Management:	Manager
ViewSonic Launcher:	Yes

POWER

Voltage:	100-240 VAC +/- 10%
Consumption:	57.27W with Energy Star

ERGONOMICS

Wall Mount (VESA®):	400x400 mm
---------------------	------------

OPERATING CONDITIONS

Temperature (° C):	0 to 40°C
Humidity:	20% ~ 80% RH non-condensing

OPERATING HOURS

24/7

DIMENSIONS (W X H X D)

Physical (inch / mm):	1118.6 x 639.2 x 62 mm
-----------------------	------------------------

WEIGHT

Net (lb / kg):	11.7kg
Gross (lb / kg):	15.96kg

REGULATIONS

cTUVus, FCC/ICES003, Energy star 8, EPEAT Silver, EEI, EMC/CE Report, CB, EAC, UkrSEPRO, RCM, Green BOM, RoHS DoC, ErP-Eco, REACH DoC, SCIP, WEEE report, Annex I, Annex II, TPCH DoC, Packing waste, CA65 DoC

PACKAGE CONTENTS

1. 3M power cord
2. Remote control
3. AAA battery x 2
4. Quick Start Guide
5. RS232 adapter
6. Wall mount Screw x 4
7. HDMI cable 3 M(HDMI LA certified)
8. Compliance statement